

**Report Number: QIP-ASI172818**

**Audit Date :** 10 Oct.,2017

This report is issued by Focus Technology Co., Ltd. (Made-in-China.com) and the supervising inspectorate (SGS-CSTC Standards Technical Services Co., Ltd.) to confirm that:

**Company Name :** Dongguan Grande Electronics Technology Co., Ltd.

东莞市宏阔电子科技有限公司

Remark: The company also used company name of Grande Electronics Technology Limited (registered in Hong Kong) in business. This Hong Kong company had same legal representative with mainland company.

**Showroom :** <http://testchamber.en.made-in-china.com>

**Address :** Hengling Industrial Zone, Nanshe Village, Chashan Town, Dongguan City, Guangdong Province, China

**Product :** Test Chamber

**has been on site audited for the Following Scope of Activity**

1. General Information
2. Foreign Trade Capacity
3. Product Research & Development Capacity
4. Management System and Product Certification
5. Production Capacity & Quality Control
6. Working Environment
7. Energy Saving and Emission Reduction
8. Photos



**General Comments:**

Dongguan Grande Electronics Technology Co., Ltd. is a manufacturer with 19 employees; it was established in 2016, located in Hengling Industrial Zone, Nanshe Village, Chashan Town, Dongguan City, Guangdong Province, China. The company occupies an area of more than 700 square meters. The company has successful foreign trading experience in Europe and North America.

Remark: CE Certificate is held by Grande Electronics Technology Limited (Associated Company).



Sign for and on behalf of  
SGS-CSTC Standards Technical Services Co., Ltd.



Unless otherwise agreed in writing, this document is issued by the Company under its General Conditions of Service accessible at <http://www.sgs.com/en/Terms-and-Conditions.aspx> Attention is drawn to the limitation of liability, indemnification and jurisdiction issues defined therein. Any holder of this document is advised that information contained hereon is solely limited to visual examination of the safely and readily accessible portions of the consignment and reflects the Company's findings at the time of its intervention only and within the limits of Client's instructions, if any. The Company's sole responsibility is to its Client and this document does not exonerate parties to a transaction from exercising all their rights and obligations under the transaction documents. Any unauthorized alteration, forgery or falsification of the content or appearance of this document is unlawful and offenders may be prosecuted to the fullest extent of the law.

Attention: To check the authenticity of testing /inspection report & certificate, please contact us at telephone: (86-755) 8307 1443, or email: [CN.Doccheck@sgs.com](mailto:CN.Doccheck@sgs.com) **Page No.: 1 of 16**

5/F, B-4 Building, Zijin (Baixia) Technology Incubation Special Park, No.1 Guanghua Road, Nanjing, China 210014 t (86-25) 87128385 f (86-25) 83407773 www.sgsgroup.com.cn  
中国·南京·秦淮区光华路1号紫金白下创业特别社区4号楼B幢5楼 邮编: 210014 t (86-25) 87128385 f (86-25) 83407773 e as.cn@sgs.com

# SUPPLIER ASSESSMENT REPORT

Audited Company	Dongguan Grande Electronics Technology Co., Ltd.
Audited Site:	Hengling Industrial Zone, Nanshe Village, Chashan Town, Dongguan City, Guangdong Province, China

Consigner of Assessment	Made-in-China.com		
Audit Type	<input checked="" type="checkbox"/> Initial Audit <input type="checkbox"/> Re-audit		
Audit Date	10 Oct.,2017	Verify Report	<a href="http://www.sgs.com/ecv">www.sgs.com/ecv</a>
Auditor	Mr. Longfei Wang	Reviewed by	Mr. Simon Wang

## CONTENTS

- Part A: General Information**
  - Section 1: Company Overview
  - Section 2: Human Resources
- Part B: Foreign Trade Capacity**
  - Section 1: Export Overall Situation
  - Section 2: Export Business Capacity
  - Section 3: Supplier Management
  - Section 4: After-sales Service Capacity
- Part C: Product Research & Development Capacity**
  - Section 1: Product Research & Development Capacity
- Part D: Management System and Product Certification**
  - Section 1: Management System(s) and Product Certification
- Part E: Production Capacity & Quality Control**
  - Section 1: Production Capacity Section
  - Section 2: Production Process Control
- Part F: Financial Position**
  - Section 1: Financial Data
  - Section 2: Key Performance Indications
  - Section 3: Banking
  - Section 4: Product Insurance
- Part G: Working Environment**
  - Section 1: Working Environment
- Part H: Energy Saving and Emission Reduction**
  - Section 1: Environmental Management
  - Section 2: Water, Gas and Noise Control
- Part I: Industry Information**
  - Section 1: Industry Information
- Part J: Photos**
  - Section 1: Photos of Documents
  - Section 2: Photos of Company



Unless otherwise agreed in writing, this document is issued by the Company under its General Conditions of Service accessible at <http://www.sgs.com/en/Terms-and-Conditions.aspx>. Attention is drawn to the limitation of liability, indemnification and jurisdiction issues defined therein. Any holder of this document is advised that information contained hereon is solely limited to visual examination of the safely and readily accessible portions of the consignment and reflects the Company's findings at the time of its intervention only and within the limits of Client's instructions, if any. The Company's sole responsibility is to its Client and this document does not exonerate parties to a transaction from exercising all their rights and obligations under the transaction documents. Any unauthorized alteration, forgery or falsification of the content or appearance of this document is unlawful and offenders may be prosecuted to the fullest extent of the law.

Attention: To check the authenticity of testing/inspection report & certificate, please contact us at telephone: (86-755) 8307 1443, or email: [CN.Doccheck@sgs.com](mailto:CN.Doccheck@sgs.com)

Page No.: 2 of 16

SGS-CSI Standards Technical Services Co., Ltd.  
Consumer and

5/F, B-4 Building, Zjin (Baixia) Technology Incubation Special Park, No.1 Guanghua Road, Nanjing, China 210014 t (86-25) 87128385 f (86-25) 83407773 www.sgs.com.cn  
中国·南京·秦淮区光华路1号紫金白下创业特别社区4号楼B幢5楼 邮编: 210014 t (86-25) 87128385 f (86-25) 83407773 e as.cn@sgs.com

## Part A: General Information

### Section 1: Company Overview

1.1 Legal Validity			
Does the company have a valid business license?	<input checked="" type="checkbox"/> Yes <input type="checkbox"/> No <input type="checkbox"/> Others	Registration Number	91441900MA4UU5711C
Year of established	30 Aug.,2016	Valid Date	Long Valid
Registered address	Hengling Industrial Zone, Nanshe Village, Chashan Town, Dongguan City, Guangdong Province, China		
Actual address	Hengling Industrial Zone, Nanshe Village, Chashan Town, Dongguan City, Guangdong Province, China		
Does the company in abnormal operation status list of industrial and commercial bureau?	No		
Registered capital	1000000 RMB		
Name of legal representative	Mr. Changqin Zhao		
Business scope	R & D, production and sales, maintenance and installation: electronic products and accessories, instruments and meters, environmental testing equipment and chamber, general machinery and equipment and accessories; import and export of goods, import and export of technology. (Projects that need to be approved by law, after approval by the relevant departments, business activities can be carried out)		
1.2 Basic Information			
Contact person	Mr. Ben Zhao		
Phone number	0086-769-87003076, 0086-15989623158	Fax number	0086-769-87008505
URL/Web address	<a href="http://www.dggrande.com">http://www.dggrande.com</a>		
Company type	<input checked="" type="checkbox"/> Manufacturer <input type="checkbox"/> Trading Company <input type="checkbox"/> Combined <input type="checkbox"/> Group Corporation		
Type of ownership	<input checked="" type="checkbox"/> Limited Company <input type="checkbox"/> Public Company <input type="checkbox"/> Foreign joint venture <input type="checkbox"/> State-Owned <input type="checkbox"/> Private Owner <input type="checkbox"/> Wholly foreign-owned enterprises		
Associated company	<ul style="list-style-type: none"> <li>■ Audited company: <b>Dongguan Grande Electronics Technology Co., Ltd.</b></li> <li>■ Associated company: <b>Grande Electronics Technology Limited</b></li> <li>■ The relationship of two companies:                             <ul style="list-style-type: none"> <li><input checked="" type="checkbox"/> The two companies have the same legal representative</li> <li><input checked="" type="checkbox"/> The two companies have the same shareholders</li> <li><input checked="" type="checkbox"/> Shareholders have 50% shares in audited company and 100% shares in associated company</li> </ul> </li> <li>■ Associated company: <b>Dongguan Risingsun Hardware &amp; Plastic Co., Ltd.</b></li> <li>■ The relationship of two companies:                             <ul style="list-style-type: none"> <li><input checked="" type="checkbox"/> The two companies have the same legal representative</li> <li><input checked="" type="checkbox"/> The two companies have the same shareholders</li> <li><input checked="" type="checkbox"/> Shareholders have 50% shares in audited company and 100% shares in associated company</li> </ul> </li> </ul>		
Products manufactured / sold scope	Test Chamber		



Unless otherwise agreed in writing, this document is issued by the Company under its General Conditions of Service accessible at <http://www.sgs.com/en/Terms-and-Conditions.aspx>. Attention is drawn to the limitation of liability, indemnification and jurisdiction issues defined therein. Any holder of this document is advised that information contained hereon is solely limited to visual examination of the safely and readily accessible portions of the consignment and reflects the Company's findings at the time of its intervention only and within the limits of Client's instructions, if any. The Company's sole responsibility is to its Client and this document does not exonerate parties to a transaction from exercising all their rights and obligations under the transaction documents. Any unauthorized alteration, forgery or falsification of the content or appearance of this document is unlawful and offenders may be prosecuted to the fullest extent of the law.

Attention: To check the authenticity of testing/inspection report & certificate, please contact us at telephone: (86-755) 8307 1443, or email: [CN.Doccheck@sgs.com](mailto:CN.Doccheck@sgs.com)

Page No.: 3 of 16

SGS-CSI Standards Technical Services Co., Ltd.  
Consumer and Industrial Technical Services

5/F, B-4 Building, Zjin (Baixia) Technology Incubation Special Park, No.1 Guanghua Road, Nanjing, China 210014 t (86-25) 87128385 f (86-25) 83407773 www.sgs.com.cn  
中国·南京·秦淮区光华路1号紫金白下创业特别社区4号楼B幢5楼 邮编: 210014 t (86-25) 87128385 f (86-25) 83407773 e as.cn@sgs.com

### 1.3 Company Building Information

According to:

- Land certificate                       Real estate certificate  
 Lease agreement                       Observation Estimated on site

The company area 700 square meters

The land occupies / square meters. (Confidential)

The offices occupy 100 square meters.

The workshops occupy 600 square meters.



SGS-CSI Standards Technical Services Co., Ltd.  
Consumer and Retailer

Unless otherwise agreed in writing, this document is issued by the Company under its General Conditions of Service accessible at <http://www.sgs.com/en/Terms-and-Conditions.aspx> Attention is drawn to the limitation of liability, indemnification and jurisdiction issues defined therein. Any holder of this document is advised that information contained hereon is solely limited to visual examination of the safely and readily accessible portions of the consignment and reflects the Company's findings at the time of its intervention only and within the limits of Client's instructions, if any. The Company's sole responsibility is to its Client and this document does not exonerate parties to a transaction from exercising all their rights and obligations under the transaction documents. Any unauthorized alteration, forgery or falsification of the content or appearance of this document is unlawful and offenders may be prosecuted to the fullest extent of the law.

Attention: To check the authenticity of testing / inspection report & certificate, please contact us at telephone: (86-755) 8307 1443, or email: [CN.Doccheck@sgs.com](mailto:CN.Doccheck@sgs.com)

Page No.: 4 of 16

5/F, B-4 Building, Zijin (Baixia) Technology Incubation Special Park, No.1 Guanghua Road, Nanjing, China 210014 t (86-25) 87128385 f (86-25) 83407773 www.sgs.com.cn  
 中国·南京·秦淮区光华路1号紫金白下创业特别社区4号楼B幢5楼 邮编: 210014 t (86-25) 87128385 f (86-25) 83407773 e as.cn@sgs.com

## Section 2: Human Resources

### 2.1 Company Chart

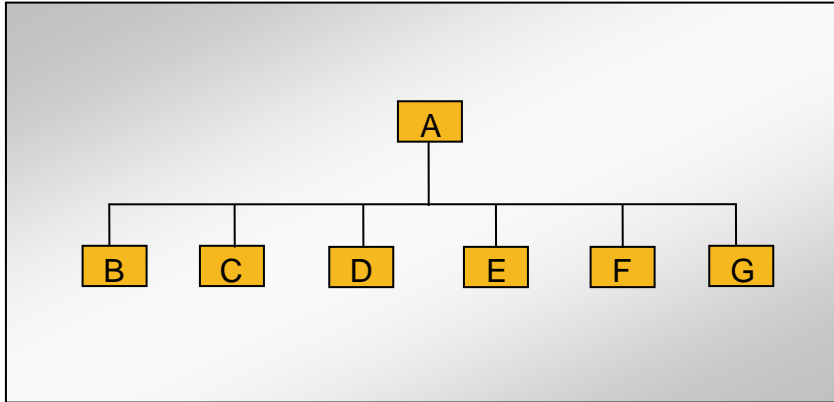

### 2.2 Explanation of Code and Employee Details

Code	Department	Number of employees
A	General Manager	1
B	Engineering Dept.	2
C	Sales Dept.	3
D	Warehouse Dept.	2
E	Production Dept.	8
F	Quality Dept.	1
G	After-Sales Service Dept.	2
<b>Number in total:</b>		19

### 2.3 Key Staff

Title	Full name	Education	Working experience for this trade / total experience
General Manager	Mr. Ben Zhao	Senior High School	6/14 years

Remark: Above information of key staff was based on interview with company representative.



Unless otherwise agreed in writing, this document is issued by the Company under its General Conditions of Service accessible at <http://www.sgs.com/en/Terms-and-Conditions.aspx>. Attention is drawn to the limitation of liability, indemnification and jurisdiction issues defined therein. Any holder of this document is advised that information contained hereon is solely limited to visual examination of the safely and readily accessible portions of the consignment and reflects the Company's findings at the time of its intervention only and within the limits of Client's instructions, if any. The Company's sole responsibility is to its Client and this document does not exonerate parties to a transaction from exercising all their rights and obligations under the transaction documents. Any unauthorized alteration, forgery or falsification of the content or appearance of this document is unlawful and offenders may be prosecuted to the fullest extent of the law.

Attention: To check the authenticity of testing/inspection report & certificate, please contact us at telephone: (86-755) 8307 1443, or email: [CN.Doccheck@sgs.com](mailto:CN.Doccheck@sgs.com)

Page No.: 5 of 16

SGS-CSI Standards Technical Services Co., Ltd.  
 Consumer and Retailer Technical Services

5/F, B-4 Building, Zjin (Baixia) Technology Incubation Special Park, No.1 Guanghua Road, Nanjing, China 210014 t (86-25) 87128385 f (86-25) 83407773 www.sgs.com.cn  
 中国·南京·秦淮区光华路1号紫金白下创业特别社区4号楼B幢5楼 邮编: 210014 t (86-25) 87128385 f (86-25) 83407773 e as.cn@sgs.com

## Part B: Foreign Trade Capacity

### Section 1: Export Overall Situation

1.1 Export Overall Situation	
Does the company have a valid Import and Export license?	<input type="checkbox"/> Yes <input checked="" type="checkbox"/> No
The import and export enterprise code.	N/A
The number of foreign trading staff with relevant trading experience.	<input type="checkbox"/> within 1 year staff <input checked="" type="checkbox"/> 1-5 years 1 staff <input checked="" type="checkbox"/> 6-10 years 3 staffs <input type="checkbox"/> over 10 years staff Total 4 staffs
The language freely used by foreign trade staff	<input checked="" type="checkbox"/> English <input checked="" type="checkbox"/> others: Spanish
Annual revenue of previous year	Confidential
Annual export revenue of previous year	Confidential
Estimated export revenue for this year.	Confidential
Overseas agent / branch	<input type="checkbox"/> Yes <input checked="" type="checkbox"/> No
Nearest port	Shenzhen Port, Guangzhou Port
Acceptable quotation terms	<input checked="" type="checkbox"/> FOB <input checked="" type="checkbox"/> CIF <input type="checkbox"/> CFR Other: EXW, DDP, DDU
Acceptable payment terms	<input checked="" type="checkbox"/> LC <input checked="" type="checkbox"/> T/T <input type="checkbox"/> D/P <input checked="" type="checkbox"/> PayPal <input checked="" type="checkbox"/> Western Union <input type="checkbox"/> Small-amount payment
Average lead time (Peak Season)	<input checked="" type="checkbox"/> within 15 workday <input type="checkbox"/> one month <input type="checkbox"/> 2-3 months <input type="checkbox"/> 4-6 months <input type="checkbox"/> 6-12 months <input type="checkbox"/> more time
Average lead time (Off Season)	<input checked="" type="checkbox"/> within 15 workday <input type="checkbox"/> one month <input type="checkbox"/> 2-3 months <input type="checkbox"/> 4-6 months <input type="checkbox"/> 6-12 months <input type="checkbox"/> more time

### Section 2: Export Business Capacity

2.1 Market Distribution (please list top three areas)		
Market	Main Product	Main client
<input checked="" type="checkbox"/> North America	Test Chamber	Confidential
<input type="checkbox"/> South America		
<input checked="" type="checkbox"/> Europe	Test Chamber	Confidential
<input type="checkbox"/> Southeast Asia/ Mideast		
<input type="checkbox"/> Africa		
<input type="checkbox"/> East Asia (Japan/ South Korea)		
<input type="checkbox"/> Australia		
<input checked="" type="checkbox"/> Domestic	Test Chamber	Confidential
<input type="checkbox"/> Others		



Unless otherwise agreed in writing, this document is issued by the Company under its General Conditions of Service accessible at <http://www.sgs.com/en/Terms-and-Conditions.aspx> Attention is drawn to the limitation of liability, indemnification and jurisdiction issues defined therein. Any holder of this document is advised that information contained hereon is solely limited to visual examination of the safely and readily accessible portions of the consignment and reflects the Company's findings at the time of its intervention only and within the limits of Client's instructions, if any. The Company's sole responsibility is to its Client and this document does not exonerate parties to a transaction from exercising all their rights and obligations under the transaction documents. Any unauthorized alteration, forgery or falsification of the content or appearance of this document is unlawful and offenders may be prosecuted to the fullest extent of the law.

Attention: To check the authenticity of testing/inspection report & certificate, please contact us at telephone: (86-755) 8307 1443, or email: [CN.Doccheck@sgs.com](mailto:CN.Doccheck@sgs.com)

Page No.: 6 of 16

SGS-CSI Standards Technical Services Co., Ltd.  
Consumer and Industrial

5/F, B-4 Building, Zijin (Baixia) Technology Incubation Special Park, No.1 Guanghua Road, Nanjing, China 210014 t (86-25) 87128385 f (86-25) 83407773 www.sgsgroup.com.cn  
中国·南京·秦淮区光华路1号紫金白下创业特别社区4号楼B幢5楼 邮编: 210014 t (86-25) 87128385 f (86-25) 83407773 e as.cn@sgs.com

### Section 3: Supplier Management

3.1 Supplier Management		
Item	Content	Observations /Comments
1	Does the company establish and implement an effective suppliers' assessment procedure?	<input type="checkbox"/> Have the written procedures and followed records <input type="checkbox"/> Have the written procedures but no records <input type="checkbox"/> Have relevant records without written procedure <input checked="" type="checkbox"/> No written procedures or followed records <input type="checkbox"/> Other
2	Does the company have an updated list of approved suppliers?	<input type="checkbox"/> The approved suppliers list was updated in _____ <input type="checkbox"/> Have the written suppliers without approved signature or date. <input checked="" type="checkbox"/> Provided some suppliers names <input type="checkbox"/> No approved suppliers list <input type="checkbox"/> Other

### Section 4: After-sales Service Capacity

4.1 After-sales Service Capacity		
Item	Content	Observations /Comments
1	Is there a procedure to conduct random product inspection after final packaging in place?	<input checked="" type="checkbox"/> Have clear standards and written inspection records <input type="checkbox"/> No written standards but had inspection reports <input type="checkbox"/> Have the procedures but no inspection records <input type="checkbox"/> It's not necessary to carry out the inspection <input type="checkbox"/> Other
2	Is there a clear procedure for handling customer complaints?	<input type="checkbox"/> Has the clear procedure and followed records <input type="checkbox"/> Has the procedure but no written records. <input type="checkbox"/> No written procedures or records. <input checked="" type="checkbox"/> Other After-sales service dept. is responsibility for handling customer complaints
3	Can the finished/packaged product be traced by lot identification to the appropriate raw materials test reports?	<input type="checkbox"/> Have the procedures to trace the raw materials. <input checked="" type="checkbox"/> Can trace main materials <input type="checkbox"/> Can trace production date. <input type="checkbox"/> Can't trace products <input type="checkbox"/> Other
4	Are corrective & preventive actions mechanism established and implemented effectively (including the suppliers/ sub-contractors control, incoming inspection, process control, final inspection and customer complaint)?	<input type="checkbox"/> Has the clear procedure and followed records <input type="checkbox"/> Has the procedure but no written records. <input checked="" type="checkbox"/> No written procedures or records. <input type="checkbox"/> Other



Unless otherwise agreed in writing, this document is issued by the Company under its General Conditions of Service accessible at <http://www.sgs.com/en/Terms-and-Conditions.aspx> Attention is drawn to the limitation of liability, indemnification and jurisdiction issues defined therein. Any holder of this document is advised that information contained hereon is solely limited to visual examination of the safely and readily accessible portions of the consignment and reflects the Company's findings at the time of its intervention only and within the limits of Client's instructions, if any. The Company's sole responsibility is to its Client and this document does not exonerate parties to a transaction from exercising all their rights and obligations under the transaction documents. Any unauthorized alteration, forgery or falsification of the content or appearance of this document is unlawful and offenders may be prosecuted to the fullest extent of the law.

Attention: To check the authenticity of testing/inspection report & certificate, please contact us at telephone: (86-755) 8307 1443, or email: [CN.Doccheck@sgs.com](mailto:CN.Doccheck@sgs.com)

## Part C: Product Research & Development Capacity

1.1 Product Research & Development Capacity	
The amount of R&D and relevant working experience.	<input type="checkbox"/> within 1 year staff <input type="checkbox"/> 1-5 years staff <input checked="" type="checkbox"/> 6-10 years 1 staff <input checked="" type="checkbox"/> over 10 years 1 staff Total 2 engineers
What is the main job responsibility for R&D engineers?	Products design according to the requirement of client
Is there any relevant design input, output, review, verification and validation documentation available for auditor to review?	YES; The company provided many drawings to auditor for reviewing
Is there any special software or instrument used by the R&D staffs during the design process of new products? If yes, please list the main software or instrument.	YES; AutoCAD
Does the company have an effective design change control procedure in place?	NO; The company has not established an effective design change control procedure
Please list the patent certificates and qualification license.	Patent certificates: Nil; qualification certificates: Nil



Unless otherwise agreed in writing, this document is issued by the Company under its General Conditions of Service accessible at <http://www.sgs.com/en/Terms-and-Conditions.aspx>. Attention is drawn to the limitation of liability, indemnification and jurisdiction issues defined therein. Any holder of this document is advised that information contained hereon is solely limited to visual examination of the safely and readily accessible portions of the consignment and reflects the Company's findings at the time of its intervention only and within the limits of Client's instructions, if any. The Company's sole responsibility is to its Client and this document does not exonerate parties to a transaction from exercising all their rights and obligations under the transaction documents. Any unauthorized alteration, forgery or falsification of the content or appearance of this document is unlawful and offenders may be prosecuted to the fullest extent of the law.

Attention: To check the authenticity of testing/inspection report & certificate, please contact us at telephone: (86-755) 8307 1443, or email: [CN.Doccheck@sgs.com](mailto:CN.Doccheck@sgs.com)

Page No.: 8 of 16

## Part D: Management System and Product Certification

1.1 Management System and Product Certification	
Management system certification	<input type="checkbox"/> ISO9001:2008 certificate <input type="checkbox"/> ISO14001:2004 certificate <input type="checkbox"/> OHSAS18001:2007 certificate <input type="checkbox"/> TS16949 <input type="checkbox"/> SA8000 <input type="checkbox"/> Others <input checked="" type="checkbox"/> NIL
Product certification	<input checked="" type="checkbox"/> CE Certificate Name: CE NO.: HTT170709262L Product Name: Thermal Shock Test Chambers Model: GTTS-050, GLTS-041-65-LW Standard: EN60204-1:2006+A1:2009 Issued by: HTT Issue Date: 02 Aug.,2017 <input type="checkbox"/> UL <input type="checkbox"/> CCC <input type="checkbox"/> RoHS <input type="checkbox"/> FCC <input type="checkbox"/> Others <input type="checkbox"/> NIL
Test reports for raw materials	<input type="checkbox"/> RoHS <input type="checkbox"/> Reach <input type="checkbox"/> Others <input checked="" type="checkbox"/> NIL



Unless otherwise agreed in writing, this document is issued by the Company under its General Conditions of Service accessible at <http://www.sgs.com/en/Terms-and-Conditions.aspx> Attention is drawn to the limitation of liability, indemnification and jurisdiction issues defined therein. Any holder of this document is advised that information contained hereon is solely limited to visual examination of the safely and readily accessible portions of the consignment and reflects the Company's findings at the time of its intervention only and within the limits of Client's instructions, if any. The Company's sole responsibility is to its Client and this document does not exonerate parties to a transaction from exercising all their rights and obligations under the transaction documents. Any unauthorized alteration, forgery or falsification of the content or appearance of this document is unlawful and offenders may be prosecuted to the fullest extent of the law.

Attention: To check the authenticity of testing/inspection report & certificate, please contact us at telephone: (86-755) 8307 1443, or email: [CN.Doccheck@sgs.com](mailto:CN.Doccheck@sgs.com)

Page No.: 9 of 16

SGS-CTI Standards Technical Services Co., Ltd.  
Consumer and Industrial Goods

5/F, B-4 Building, Zijin (Baixia) Technology Incubation Special Park, No.1 Guanghua Road, Nanjing, China 210014 t (86-25) 87128385 f (86-25) 83407773 www.sgsgroup.com.cn  
 中国·南京·秦淮区光华路1号紫金白下创业特别社区4号楼B幢5楼 邮编: 210014 t (86-25) 87128385 f (86-25) 83407773 e as.cn@sgs.com

## Part E: Production Capacity & Quality Control

### Section 1: Production Capacity

#### 1.1 Production Workflow Chart

	→		→		→
Shearing		Bending		Cutting	
	→		→		→
Electric Welding		Assembly		Circuit System Assembly	
Testing					

#### 1.2 Products Situation (Top three Product Categories)

Product	Price range	Min. order quantity	Top monthly output	Average monthly output	Total in 2016
Test Chamber	15000-290000 RMB	1 Set	14 Sets	12 Sets	Confidential

#### 1.3 Main Facilities

Picture	Facility name	Brand or Country/Region of origin	Target Value/machine*day	Quantity
	Shearing Machine	China	Confidential	1
	Bending Machine	China	Confidential	1



## Section 2: Production Process Control

2.1 Production Process Control		
Item	Content	Observations /Comments
1	Product R&D capacity	<input type="checkbox"/> Own brand <input checked="" type="checkbox"/> ODM <input checked="" type="checkbox"/> OEM
2	Are the environmental conditions, such as tidiness and cleanliness being controlled and suitable for the operation performed?	<input type="checkbox"/> Very tidy <input checked="" type="checkbox"/> Normal <input type="checkbox"/> Need to improve <input type="checkbox"/> Very poor
3	Are the necessary items /documents provided at appropriate location and under control?	<input type="checkbox"/> Work Instructions /procedures <input type="checkbox"/> Workmanship standard /acceptance <input type="checkbox"/> Golden sample /Approval sample <input checked="" type="checkbox"/> Product picture <input type="checkbox"/> Verbal by workshop director
4	Are written instructions available for incoming material inspections /testing? Is the relevant record maintained?	<input type="checkbox"/> Has instructions and uniformly followed <input type="checkbox"/> Has instruction but no written records <input checked="" type="checkbox"/> Materials checked by storage staff
5	Are written inspections /testing instructions available for finished products? Is the relevant record maintained?	<input checked="" type="checkbox"/> Have instructions and uniformly followed <input type="checkbox"/> Have instruction but no written records <input type="checkbox"/> Finished product checked by packing staff
6	What type of inspection is used for finished products?	<input type="checkbox"/> Random inspection <input type="checkbox"/> Visual inspection <input type="checkbox"/> Function inspection <input checked="" type="checkbox"/> 100% inspection <input checked="" type="checkbox"/> Visual inspection <input checked="" type="checkbox"/> Function inspection
7	Are non-conforming units clearly marked/ segregated to prevent accidental dispatch?	<input type="checkbox"/> Marked and segregated <input type="checkbox"/> Segregated but not marked clearly <input checked="" type="checkbox"/> Not found on site
8	How are the non-conforming units handled?	<input checked="" type="checkbox"/> Repaired and re-inspection <input type="checkbox"/> Picked out <input type="checkbox"/> Used under control <input type="checkbox"/> Others



Unless otherwise agreed in writing, this document is issued by the Company under its General Conditions of Service accessible at <http://www.sgs.com/en/Terms-and-Conditions.aspx> Attention is drawn to the limitation of liability, indemnification and jurisdiction issues defined therein. Any holder of this document is advised that information contained hereon is solely limited to visual examination of the safely and readily accessible portions of the consignment and reflects the Company's findings at the time of its intervention only and within the limits of Client's instructions, if any. The Company's sole responsibility is to its Client and this document does not exonerate parties to a transaction from exercising all their rights and obligations under the transaction documents. Any unauthorized alteration, forgery or falsification of the content or appearance of this document is unlawful and offenders may be prosecuted to the fullest extent of the law.

Attention: To check the authenticity of testing /inspection report & certificate, please contact us at telephone: (86-755) 8307 1443, or email: [CN.Doccheck@sgs.com](mailto:CN.Doccheck@sgs.com)

Page No.: 11 of 16

SGS-CSI Standards Technical Services Co., Ltd.  
Consumer and Technical Services

5/F, B-4 Building, Zijin (Baixia) Technology Incubation Special Park, No.1 Guanghua Road, Nanjing, China 210014 t (86-25) 87128385 f (86-25) 83407773 www.sgsgroup.com.cn  
中国·南京·秦淮区光华路1号紫金白下创业特别社区4号楼B幢5楼 邮编: 210014 t (86-25) 87128385 f (86-25) 83407773 e as.cn@sgs.com

## Part G: Working Environment

### Section 1: Working Environment

1.1 Welfare Benefits		
Item	Content	Observations /Comments
1	Does the company have effective procedures to verify the age of staff at the time of recruitment?	<input checked="" type="checkbox"/> Has written procedure and keeps adequate age documents of workers <input type="checkbox"/> Has written procedure but doesn't follow records <input type="checkbox"/> Hasn't written procedure or follows records
2	Do all workers sign employment contracts with the factory?	<input type="checkbox"/> All workers sign employment contracts <input type="checkbox"/> Some workers sign employment contracts <input type="checkbox"/> Only management staff sign employment contracts <input checked="" type="checkbox"/> No staff sign employment contracts
3	Is statutory contribution required for all employees' social insurance (e.g. health insurance, unemployment insurance, accident insurance etc.) paid for by the enterprise?	<input type="checkbox"/> All workers have social insurance. <input type="checkbox"/> Some workers have social insurance <input checked="" type="checkbox"/> Only management staffs have social insurance <input type="checkbox"/> No staff have social insurance
4	Does the company have a clear and effective policy on working hours, rest and vacations? If does, please list it.	<input type="checkbox"/> All staffs work kept to the policy <input type="checkbox"/> Most of the time it keeps to the policy except midseason. <input checked="" type="checkbox"/> Usually needs overtime. <input type="checkbox"/> No relevant records for working hours Describe the working hours: AM: 8:00-12:00, PM: 13:30-17:30, work 6 days per week, overtime is 40-60 hours per month
5	Does the company pay extra remunerations for all overtime work?	<input checked="" type="checkbox"/> For all overtime work. <input type="checkbox"/> For official holidays <input type="checkbox"/> For official holidays except weekend. <input type="checkbox"/> No extra remunerations for overtime.
6	Does the company have dormitories for staff? If yes, please describe the condition.	<input checked="" type="checkbox"/> Provide dormitories for all staff <input type="checkbox"/> Provide dormitories for workers <input type="checkbox"/> Provide dormitories for management staff <input type="checkbox"/> No dormitories were provided. Describe the condition: 1 staff live in a room
1.2 Labor Protection		
Item	Content	Observations /Comments
1	Are there uniforms for all staff in company?	<input checked="" type="checkbox"/> Yes <input type="checkbox"/> No <input type="checkbox"/> Other
2	Is the emergency medical supplies enough and easily used in workshop?	<input type="checkbox"/> Yes <input checked="" type="checkbox"/> No <input type="checkbox"/> Other
3	Does the company arrange health and safety training for new workers?	<input type="checkbox"/> Yes <input checked="" type="checkbox"/> No <input type="checkbox"/> Other
4	Do the workers have the appropriate protective equipment during operation in workshop? Such as gloves, masks.	<input checked="" type="checkbox"/> Yes <input type="checkbox"/> No <input type="checkbox"/> Other
5	Is there training needed and carried out for fire protection?	<input type="checkbox"/> Yes <input checked="" type="checkbox"/> No <input type="checkbox"/> Other

## Part H: Energy Saving and Emission Reduction

### Section 1: Environmental Management

1.1 Environmental Management		
Item	Content	Observations /Comments
1	Environmental Management System	<input type="checkbox"/> ISO 14001 Certificate <input type="checkbox"/> Cleaner production management <input checked="" type="checkbox"/> NIL
2	Environmental Impact Assessment	<input type="checkbox"/> The Report of Environmental impact assessment is approved by EPA . <input checked="" type="checkbox"/> NIL
3	Check and Acceptance of Completed Constructive Projects	<input type="checkbox"/> The Report Completed Constructive Projects Inspection and Acceptance is approved. <input checked="" type="checkbox"/> NIL
4	"Three Simultaneity" for Environmental protection	<input type="checkbox"/> The Report of "Three Simultaneity" for Environmental protection Inspection and Acceptance is available. <input checked="" type="checkbox"/> NIL

### Section 2: Water, Gas and Noise Control

2.1 Water, Gas and Noise Control		
Item	Content	Observations /Comments
1	Water-intaking	<input type="checkbox"/> Water-intaking license <input type="checkbox"/> No water-intaking license <input checked="" type="checkbox"/> No water taken from natural water body
2	Waste water	<input type="checkbox"/> Water-draining license or contract <input type="checkbox"/> Having carried out waste water treatment before draining <input type="checkbox"/> Having carried out waste water monitoring and the result of which being within the standard limit <input checked="" type="checkbox"/> No detail activities were found
3	Emission to air	<input type="checkbox"/> Air pollutant emission license <input type="checkbox"/> Having carried out air pollutant emission monitoring and the result of which being within the standard limit <input checked="" type="checkbox"/> No detail activities were found to reduce emission to air
4	Classification and Recycling for solid waste	<input checked="" type="checkbox"/> Having applied trash classification recycling <input type="checkbox"/> Having special warehouse for hazardous waste <input type="checkbox"/> No detail activities were found
5	Noise	<input type="checkbox"/> The company carried out noise monitoring and the result of which being within the standard limit one time per year <input checked="" type="checkbox"/> No detail activities were found



Unless otherwise agreed in writing, this document is issued by the Company under its General Conditions of Service accessible at <http://www.sgs.com/en/Terms-and-Conditions.aspx> Attention is drawn to the limitation of liability, indemnification and jurisdiction issues defined therein. Any holder of this document is advised that information contained hereon is solely limited to visual examination of the safely and readily accessible portions of the consignment and reflects the Company's findings at the time of its intervention only and within the limits of Client's instructions, if any. The Company's sole responsibility is to its Client and this document does not exonerate parties to a transaction from exercising all their rights and obligations under the transaction documents. Any unauthorized alteration, forgery or falsification of the content or appearance of this document is unlawful and offenders may be prosecuted to the fullest extent of the law.

Attention: To check the authenticity of testing/inspection report & certificate, please contact us at telephone: (86-755) 8307 1443, or email: [CN.Doccheck@sgs.com](mailto:CN.Doccheck@sgs.com)

Page No.: 13 of 16

SGS-CSI Standards Technical Services Co., Ltd.  
Consumer and Industrial

5/F, B-4 Building, Zijin (Baixia) Technology Incubation Special Park, No.1 Guanghua Road, Nanjing, China 210014 t (86-25) 87128385 f (86-25) 83407773 www.sgs.com.cn  
 中国·南京·秦淮区光华路1号紫金白下创业特别社区4号楼B幢5楼 邮编: 210014 t (86-25) 87128385 f (86-25) 83407773 e as.cn@sgs.com

## Part J: Photos

### Section 1: Photos of Documents

#### 1.1 Photos of Documents

Description: Business License	Description: Lease Agreement
<p>营业执照 (副本) 编号: N9 8787251 统一社会信用代码: 91441900MA4U5711C 名称: 东莞市宏康电子科技有限公司 类型: 有限责任公司 法定代表人: 赵海如 注册资本: 人民币壹佰万元 成立日期: 2016年08月30日 营业期限: 长期 经营范围: 研发、产销、维修、安装: 电子产品及配件; 仪器仪表、环境检测设备; 通用机械设备; 仪器仪表; 机电配件。 依法须经批准的项目, 经相关部门批准后方可开展经营活动。</p>	<p>厂房租赁合同</p> <p>甲方: 东莞市宏康电子科技有限公司 乙方: 东莞市宏康电子科技有限公司</p> <p>乙方租赁甲方厂房地址: 东莞市宏康电子科技有限公司</p> <p>乙方租赁甲方厂房地址: 东莞市宏康电子科技有限公司</p>



Unless otherwise agreed in writing, this document is issued by the Company under its General Conditions of Service accessible at <http://www.sgs.com/en/Terms-and-Conditions.aspx>. Attention is drawn to the limitation of liability, indemnification and jurisdiction issues defined therein. Any holder of this document is advised that information contained hereon is solely limited to visual examination of the safely and readily accessible portions of the consignment and reflects the Company's findings at the time of its intervention only and within the limits of Client's instructions, if any. The Company's sole responsibility is to its Client and this document does not exonerate parties to a transaction from exercising all their rights and obligations under the transaction documents. Any unauthorized alteration, forgery or falsification of the content or appearance of this document is unlawful and offenders may be prosecuted to the fullest extent of the law.

Attention: To check the authenticity of testing/inspection report & certificate, please contact us at telephone: (86-755) 8307 1443, or email: [CN.Doccheck@sgs.com](mailto:CN.Doccheck@sgs.com)

Page No.: 14 of 16

5F, B-4 Building, Zijin (Baixia) Technology Incubation Special Park, No.1 Guanghua Road, Nanjing, China 210014 t (86-25) 87128385 f (86-25) 83407773 www.sgs.com.cn  
 中国·南京·秦淮区光华路1号紫金白下创业特别社区4号楼B幢5楼 邮编: 210014 t (86-25) 87128385 f (86-25) 83407773 e as.cn@sgs.com

## Section 2: Photos of Company

### 2.1 Photos of Company and Product Sample

<p>Description: Company Name</p>	<p>Description: Office</p>
	
<p>Description: Workshop</p>	<p>Description: Workshop</p>
	
<p>Description: Workshop</p>	<p>Description: Product Sample</p>
	



Unless otherwise agreed in writing, this document is issued by the Company under its General Conditions of Service accessible at <http://www.sgs.com/en/Terms-and-Conditions.aspx>. Attention is drawn to the limitation of liability, indemnification and jurisdiction issues defined therein. Any holder of this document is advised that information contained hereon is solely limited to visual examination of the safely and readily accessible portions of the consignment and reflects the Company's findings at the time of its intervention only and within the limits of Client's instructions, if any. The Company's sole responsibility is to its Client and this document does not exonerate parties to a transaction from exercising all their rights and obligations under the transaction documents. Any unauthorized alteration, forgery or falsification of the content or appearance of this document is unlawful and offenders may be prosecuted to the fullest extent of the law.

Attention: To check the authenticity of testing/inspection report & certificate, please contact us at telephone: (86-755) 8307 1443, or email: [CN.Doccheck@sgs.com](mailto:CN.Doccheck@sgs.com)

Page No.: 15 of 16

5/F, B-4 Building, Zijin (Baixia) Technology Incubation Special Park, No.1 Guanghua Road, Nanjing, China 210014 t (86-25) 87128385 f (86-25) 83407773 www.sgs.com.cn  
 中国·南京·秦淮区光华路1号紫金白下创业特别社区4号楼B幢5楼 邮编: 210014 t (86-25) 87128385 f (86-25) 83407773 e as.cn@sgs.com



-- End of the Report --



Unless otherwise agreed in writing, this document is issued by the Company under its General Conditions of Service accessible at <http://www.sgs.com/en/Terms-and-Conditions.aspx>. Attention is drawn to the limitation of liability, indemnification and jurisdiction issues defined therein. Any holder of this document is advised that information contained hereon is solely limited to visual examination of the safely and readily accessible portions of the consignment and reflects the Company's findings at the time of its intervention only and within the limits of Client's instructions, if any. The Company's sole responsibility is to its Client and this document does not exonerate parties to a transaction from exercising all their rights and obligations under the transaction documents. Any unauthorized alteration, forgery or falsification of the content or appearance of this document is unlawful and offenders may be prosecuted to the fullest extent of the law.

Attention: To check the authenticity of testing/inspection report & certificate, please contact us at telephone: (86-755) 8307 1443, or email: [CN.Doccheck@sgs.com](mailto:CN.Doccheck@sgs.com)

Page No.: 16 of 16

SGS-CSI Standards Technical Services Co., Ltd.  
Consumer and Retailer Technical Services

5/F, B-4 Building, Zijin (Baixia) Technology Incubation Special Park, No.1 Guanghua Road, Nanjing, China 210014 t (86-25) 87128385 f (86-25) 83407773 www.sgsgroup.com.cn  
中国·南京·秦淮区光华路1号紫金白下创业特别社区4号楼B幢5楼 邮编: 210014 t (86-25) 87128385 f (86-25) 83407773 e as.cn@sgs.com